

High Efficiency Joint

HEJ 50-48-30

30 V – 60 V | 28 Nm | 26 rad/s

This is a highly compact, integrated and efficient robotic drive system that contains all subsystems to provide a full motion solution, such as controller, motor, gearing and sensing. This drive is enclosed, impact-rated, and designed for continuous operation at very low losses. It offers high robustness and a long operating lifetime. Controlled via *EtherCAT*, it features an advanced impedance controller, rendering it suitable for modern robotics applications. Simulation models enable dependable robotic system designs.



All data are provided for $U_{DC} = 48\text{ V}$ and $T_{amb} = 25^\circ\text{C}$, unless otherwise specified.

Specifications for different voltage levels or other operating limits, and corresponding simulation models, are available upon request.

OUTPUT CHARACTERISTICS

Maximum joint velocity	$U_{DC} = 48\text{V}$	+/- 21 rad/s
	$U_{DC} = 60\text{V}$	+/- 26 rad/s
Maximum joint torque, actively controlled & repetitive This torque can be applied for ca. 1s-2s before the temperature protection activates.		+/- 28 Nm
Nominal joint torque This torque can be maintained <i>indefinitely</i> without external forced air cooling. Conditions: Actuator mounted in free space and with a joint velocity of 2 rad/s. The time constants are long, i.e., considerably higher quasi-continuous torques can be applied for durations up to a few minutes.		+/- 11 Nm

POWER CONVERSION CHARACTERISTICS Motor Operating Quadrants

U_{DC} (V) DC-Link Voltage	V_{joint} (rad/s) Joint Velocity	M_{joint} (Nm) Joint Torque	I_{in} (A) DC-Link Input Curr.	P_{loss} (W) Total System Loss	Efficiency (%) $P_{out,mech} / P_{in,elec}$	
48	0	0	0.04	2.0	0	●
48	0	29	3.1	184	0	▲
48	0	20	1.1	65	0	▲
48	0	15	0.6	36	0	▲
48	0	10	0.3	17	0	●
48	0	5	0.1	6	0	●
48	10	0	0.3	19	0	●
48	10	25	7.3	190	57	▲
48	10	20	5.2	114	64	▲
48	15	0	0.5	30	0	●
48	15	20	7.2	133	69	▲
48	15	10	3.5	61	71	▲
48	20	0	0.7	43	0	▲
48	20	5	2.6	56	64	▲
60	25	0	0.96	58	0	●
60	25	10	3.8	77	66	▲

Operating points with a triangle (▲) can only be maintained for short times (some seconds, due to thermal limitations (mainly: continuous input current limited to $4.7 A_{RMS}$)).

Operating points marked with a circle (●) can be maintained continuously but potentially require adequate external forced air cooling.

POWER CONVERSION PERFORMANCE MAP Motor Operating Quadrants

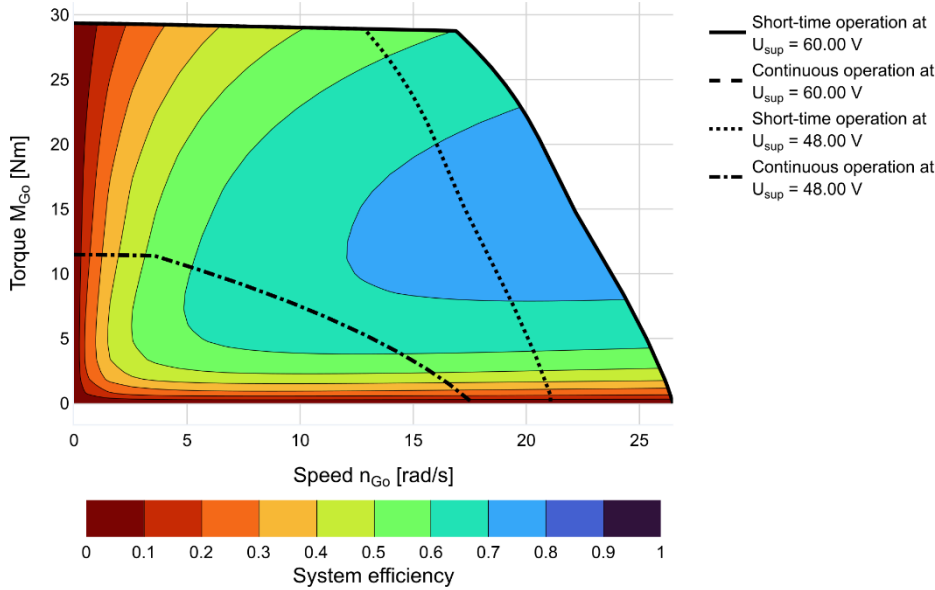

Note: This graphic shows the maximum achievable joint torque/velocities for the given supply voltages. Refer to the Power Conversion Characteristics table above for details about the continuous operating points. This plot assumes passive cooling and does not consider DC-link input current limits! Further details are available on request.

Highest efficiency, motor quadrant: 74.1%.

ELECTRICAL CHARACTERISTICS

Operating input voltage range (voltages as low as 20V are possible but can have implications – contact us.)	30 V – 60 V
Max. allowable transient input voltage (e.g., due to inductive spikes or noise on the supply bus)	67.0 V
DC link input capacitance (MLCC)	100 μ F
Max. power supply input current During transients or accelerations, the system can create high current peaks. Capacitive inrush current not considered. Unloaded joint.	< 40 A
Max. continuous power supply current Input currents may only exceed this value for very short periods of time to prevent damage to the power connector or internal cabling.	4.7 A _{RMS}

CONTROL CHARACTERISTICS

Control modes	Joint position, velocity, torque, motor current (FOC) Joint impedance controller (simultaneous control of position, velocity, torque) PDO-mappable control gains Internal cogging, friction and backlash compensation systems
Joint position sensor	Type: Absolute Single-Turn. Resolution: 14 bit. Absolute angular error: < 0.01 rad (0.6°). Note that the firmware applies sensor fusion techniques to reduce noise and INL error on this encoder signal. This sensor measures the absolute output position (after the gear).
Joint torque measurement Via electric motor current, compensated	Absolute error, steady-state: < 0.8 Nm
Joint velocity filtering	Configurable lowpass
Controller execution rate	Current controller (FOC): 25 kHz All others: 2.5 kHz PWM frequency: 50 kHz
Max. EtherCAT communication rate	1 kHz
Internal temperature sensors	Motor winding and power electronics, PDO-mappable
Motor temperature i2t protection	Configurable
Mechanical backlash Fixed motor position, movement of the joint.	0.5° (average) A backlash compensator is available in firmware. A low-backlash hardware design is available upon request.
Tot. mech. moment of inertia, at joint	56 kgcm ²
Backdriving torque (system disabled, including joint seal friction)	< 0.8 Nm

ENVIRONMENTAL CHARACTERISTICS

Ingress protection	The default configuration of this drive (P/N 922156) does not come with an ingress-protected back-cap. The PCB-mounted connectors are exposed to the elements. IP-sealed back-covers with industrial connectors are available upon request. All other IP seals are always mounted in the default unit (P/N 922156).
Ambient operating temperature	-20°C to +60°C (might require adequate cooling if the system exhibits losses)
Thermal interface Note: The thermal dissipation capability serves only as an indication. Actual performance depends on external heat transfer system and environment. Details are available upon request.	Integrated heat sinks for forced air cooling. Continuous thermal dissipation (passive convective cooling) up to ca. 36 W.
Thermal resistance winding-housing	1.4 K/W
Thermal time constant winding	15.9 s

LIFETIME CHARACTERISTICS

Note: A high emphasis was put on creating a highly reliable and robust product. Nonetheless, the operating lifetime of this drive strongly depends on its load cases and environmental aspects. The indicated values are only a (simplified) guideline. Further details are available upon request.

High-cycle fatigue: Joint impact/overtorque events	12e6 impacts at 23 Nm 100e3 impacts at 30 Nm 1e3 impacts at 40 Nm
Lifetime at constant operation Note 1: Depending on environmental factors (e.g., temperature, dust or chemicals exposure), the joint output seal may potentially degrade earlier. Note 2: These operating points are naturally dependent on temperature and specific aspects of the load cycle and gear lubrication life. Details can be provided upon request.	10 Nm, 22 rad/s: >56'000 h 30 Nm, 5 rad/s: >56'000 h

MECHANICAL CHARACTERISTICS

Axial length	ca. 65 mm
Diameter	ca. 71.5 mm
Mass	0.53 kg
Cross-roller joint output bearing The system provides an integrated cross-roller bearing. Its load cases can be complex. Contact us for assistance, especially regarding acceptable safety factors. A stronger cross-roller bearing is available upon request.	Bearing: THK RAU4005 or similar. Dia = 51 mm, C=2140 N, C ₀ =2740 N

ELECTRICAL INTERFACES

Connectors:	1x Power supply, 2x <i>EtherCAT</i> (allows daisy-chaining of several systems), 1x USB (only for debugging/testing). IP67-rated covers with industrial connectors are available upon request.
<i>EtherCAT</i>	Full Duplex, 100 Mbit/s
Functional safety	Under development. Please contact us for details.
Grounding concept	All housing parts connected to DC link GND via RC network. Provision to connect <i>EtherCAT</i> shield to housing.

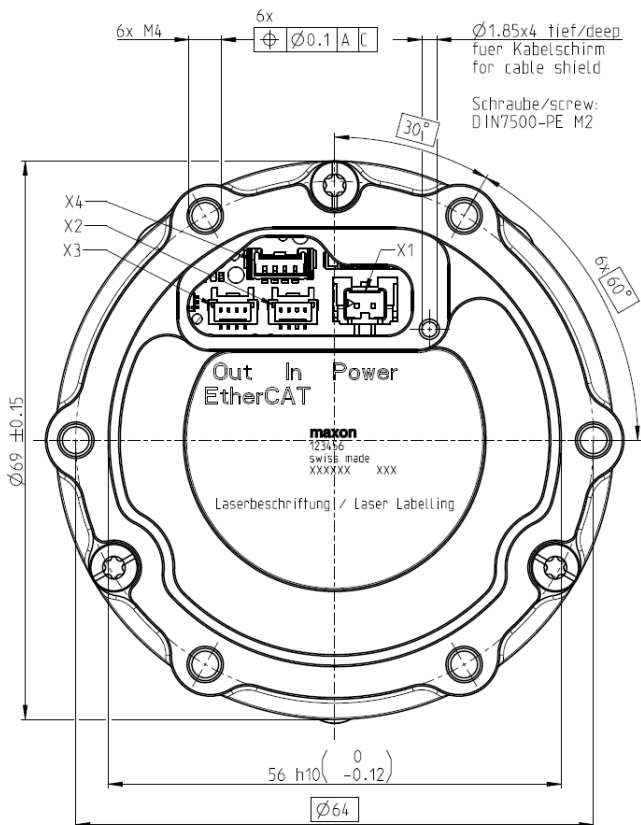
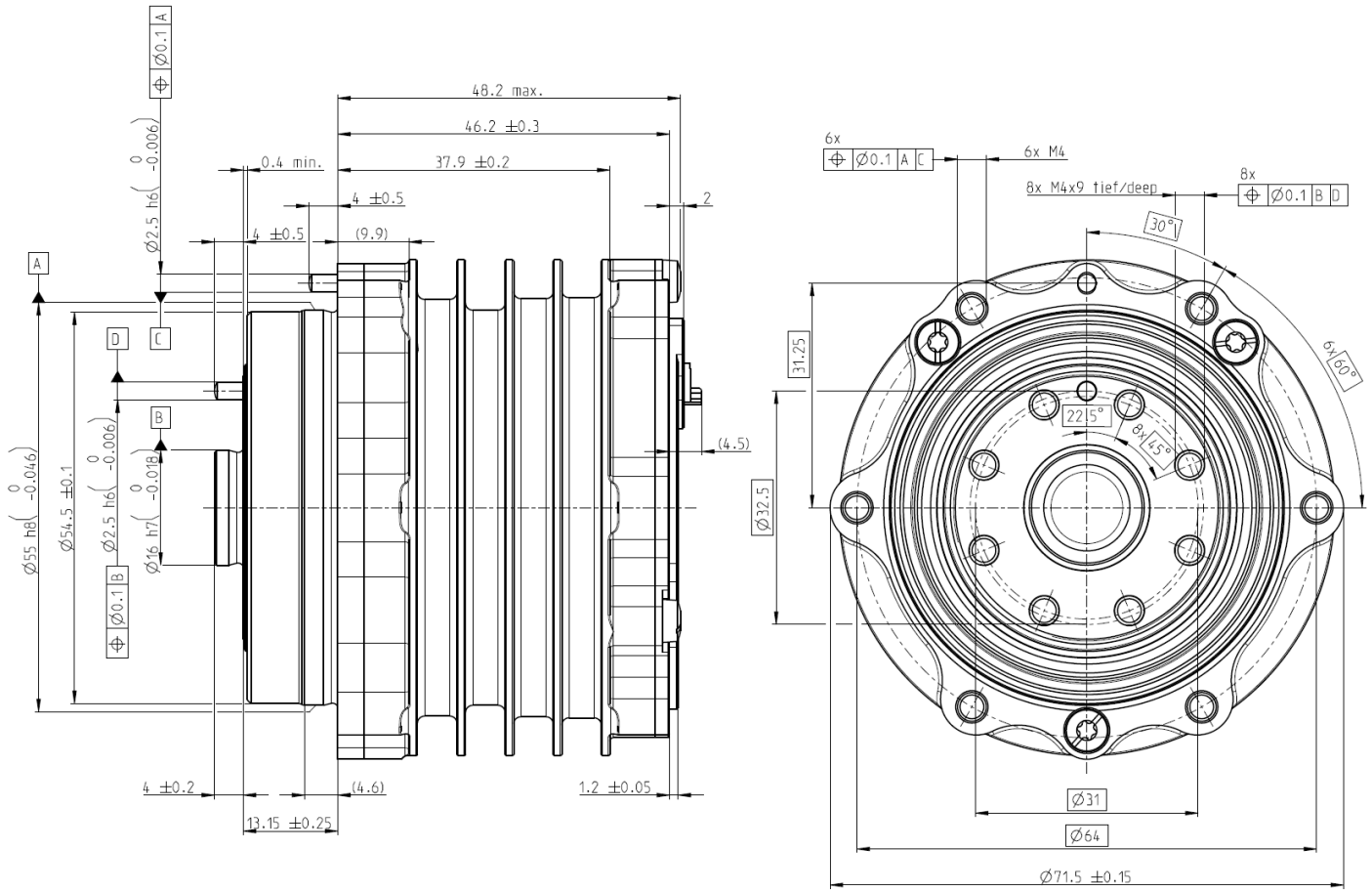

MECHANICAL DRAWINGS



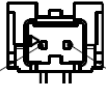

Note 1: maxon can offer customized housing geometries, e.g., different thread sizes, hole patterns, or attachment points. Please contact robotics@maxongroup.com

Note 2: The HEJ 50 can also be mounted solely at its rear interface (6x M4 fasteners). Please contact us at robotics@maxongroup.com to assess your load case (force transmission, housing integrity, high-cycle fatigue).

ELECTRICAL PINOUTS

Steckerbelegung / PIN allocation		
Stecker/connector	PIN	Signal
X1 Power Molex Micro-Lock Plus 505575-0281 	1	VBUS
	2	GND
X2 EtherCAT In Molex Pico-Clasp 501940-0407 	1	TX+
	2	TX-
	3	RX+
	4	RX-

Steckerbelegung / PIN allocation		
Stecker/connector	PIN	Signal
X3 EtherCAT Out Molex Pico-Clasp 501940-0407 	1	TX+
	2	TX-
	3	RX+
	4	RX-
X4 USB Molex Micro-Lock Plus 505568-0471 	1	Vcc 5V
	2	Data -
	3	Data +
	4	GND

Please note: IP67-rated rear covers with industrial connectors are available upon request.