

High Efficiency Joint

HEJ 90-48-140

30 V – 60 V | 140 Nm | 13 rad/s

This is a highly compact, integrated and efficient robotic drive system that contains all subsystems to provide a full motion solution, such as controller, motor, gearing and sensing. This drive is fully enclosed, ingress- and impact-rated, and designed for continuous operation at very low losses. It offers high robustness and a long operating lifetime. Controlled via *EtherCAT*, it features an advanced impedance controller, rendering it suitable for modern robotics applications.

Simulation models enable dependable robotic system designs.



EtherCAT[®]

All data are provided for $U_{DC} = 48\text{ V}$ and $T_{amb} = 25^\circ\text{C}$, unless otherwise specified.

Specifications for different voltage levels or other operating limits, and corresponding simulation models, are available upon request.

OUTPUT CHARACTERISTICS

Maximum joint velocity	$U_{DC} = 48\text{V}$	+/- 10.4 rad/s
	$U_{DC} = 60\text{V}$	+/- 13.0 rad/s
Maximum joint torque, actively controlled & repetitive <small>This torque can be applied for ca. 4s-5s before the temperature protection activates.</small>	+/- 140 Nm <small>(+/- 180 Nm-variant available upon request)</small>	
Nominal joint torque <small>This torque can be maintained indefinitely without external forced air cooling. Conditions: Actuator mounted in free space and with a joint velocity of 2 rad/s. The time constants are long, i.e., considerably higher quasi-continuous torques can be applied for durations up to a few minutes.</small>	+/- 75 Nm	

POWER CONVERSION CHARACTERISTICS Motor Operating Quadrants

U_{DC} (V) DC-Link Voltage	V_{joint} (rad/s) Joint Velocity	M_{joint} (Nm) Joint Torque	I_{in} (A) DC-Link Input Curr.	P_{loss} (W) Total System Loss	Efficiency (%) $P_{out,mech} / P_{in,elec}$	
48	0	0	0.04	2.2	0	●
48	0	140	13.8	664.1	0	▲
48	0	80	3.6	172.9	0	▲
48	0	60	1.9	92.0	0	●
48	0	30	0.5	24.2	0	●
48	5	100	17.7	350.4	59	▲
48	5	140	30.1	744.0	48	▲
48	6	50	8.4	105.2	74	▲
48	6	100	20.0	362.1	62	▲
48	6	135	31.3	693.5	54	▲
48	8	50	10.8	119.8	77	▲
48	8	100	24.7	385.7	67	▲
48	10	25	6.5	66.1	79	●
60	6	135	25.0	693.5	54	▲
60	10.5	100	23.7	396.5	72	▲
60	12	50	12.5	150.0	80	▲
60	13	0	0.6	38.1	0	●

Operating points with a triangle (▲) can only be maintained for short times (some seconds, due to thermal limitations (mainly: continuous input current limited to 8 A_{RMS})).

Operating points marked with a circle (●) can be maintained continuously but potentially require adequate external forced air cooling.

POWER CONVERSION PERFORMANCE MAP Motor Operating Quadrants

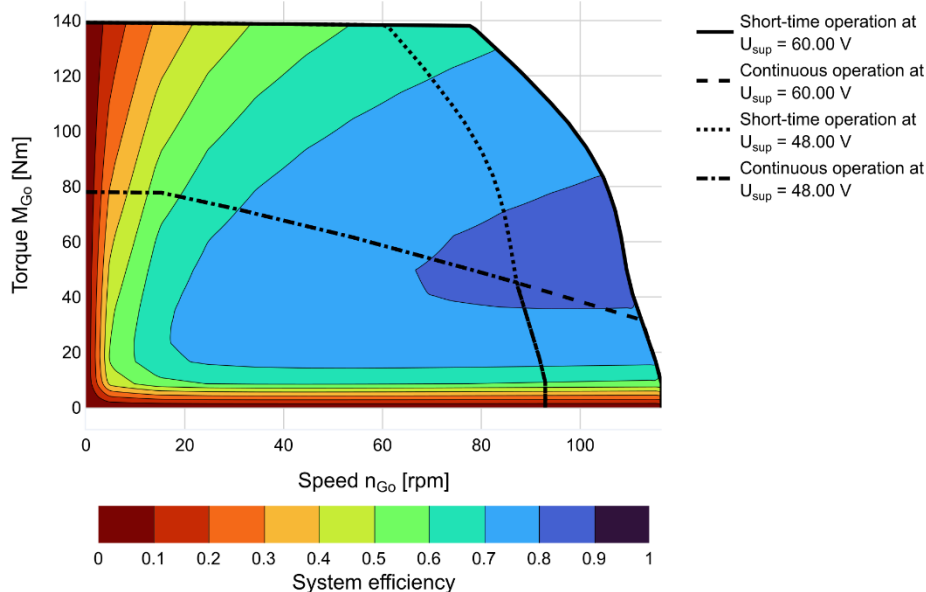

Note: This graphic shows the maximum achievable joint torque/velocities for the given supply voltages. Refer to the *Power Conversion Characteristics* table above for details about the continuous operating points. This plot assumes passive cooling and does *not* consider DC-link input current limits! Further details are available on request.

Highest efficiency, motor quadrant: ca. 86.1%

ELECTRICAL CHARACTERISTICS

Operating input voltage range (voltages as low as 20V are possible but can have implications – contact us.)	30 V – 60 V
Max. allowable transient input voltage (e.g., due to inductive spikes or noise on the supply bus)	67.0 V
DC link input capacitance	165 μF
Max. power supply input current During transients or accelerations, the system can create high current peaks. Capacitive inrush current not considered. Unloaded joint.	< 40 A
Max. continuous power supply current Input currents may only exceed this value for very short periods of time to prevent damage to the power connector or internal cabling. Please approach us if you plan on exceeding this limit.	8.0 A _{RMS}

CONTROL CHARACTERISTICS

Control modes	Joint position, velocity, torque, motor current (FOC) Joint impedance controller (simultaneous control of position, velocity, torque) PDO-mappable control gains Internal cogging, friction and backlash compensation systems
Joint position sensor	Type: Absolute Single-Turn. Resolution: 12 bit. Absolute angular error: < 0.008 rad (0.5°). Note that the firmware applies sensor fusion techniques to reduce noise and INL error on this encoder signal. This sensor measures the absolute output position (after the gear).
Joint torque measurement Via electric motor current, compensated	Absolute error, steady-state: < 1.5 Nm
Joint velocity filtering	Configurable lowpass
Controller execution rate	Current controller (FOC): 25 kHz All others: 2.5 kHz PWM frequency: 50 kHz
Max. EtherCAT communication rate	1 kHz
Internal temperature sensors	Motor winding and power electronics, PDO-mappable
Motor temperature i2t protection	Configurable
Mechanical backlash Fixed motor position, movement of the joint.	0.5° (average) A backlash compensator is available in firmware. A low-backlash hardware design is available upon request.
Tot. mech. moment of inertia, at joint	0.045 kgm ²
Backdriving torque (system disabled, including joint seal friction)	< 1.5 Nm
Acceleration time	< 8 ms Time it takes to accelerate the joint from standstill to its maximum velocity.

ENVIRONMENTAL CHARACTERISTICS	
Ingress protection	IP67, also with rotating joint and applied bending moments
Ambient operating temperature	-20°C to +60°C (might require adequate cooling if the system exhibits losses)
Thermal interface Note: The thermal dissipation capability serves only as an indication. Actual performance depends on external heat transfer system and environment. Details are available upon request.	Integrated heat sinks for forced air cooling. Continuous thermal dissipation (active cooling) up to ca. 250 W. Integrated and user-controllable fan power supply.
Thermal resistance winding-housing	0.3 K/W
Thermal time constant winding	21 s

LIFETIME CHARACTERISTICS	
Note: A high emphasis was put on creating a highly reliable and robust product. Nonetheless, the operating lifetime of this drive strongly depends on its load cases and environmental aspects. The indicated values are only a (simplified) guideline. Further details are available upon request.	
High-cycle fatigue: Joint impact/overtorque events	12e6 impacts at 180 Nm 100e3 impacts at 240 Nm 1e3 impacts at 320 Nm
Lifetime at constant operation Note 1: Depending on environmental factors (e.g., temperature, dust or chemicals exposure), the joint output seal may potentially degrade earlier. Note 2: These operating points are naturally dependent on temperature and specific aspects of the load cycle and gear lubrication life. Details can be provided upon request.	30 Nm, 10 rad/s: 56'000 h 60 Nm, 5 rad/s: 14'000 h

MECHANICAL CHARACTERISTICS	
Axial length, overall, excluding connectors	ca. 90 mm
Diameter, excluding connectors	ca. 108 mm
Mass	2.006 kg (radial version) 1.987 kg (axial version)
Cross-roller joint output bearing The system provides an integrated cross-roller bearing. Its load cases can be complex. Contact us for assistance, especially regarding acceptable safety factors. A stronger cross-roller bearing is available upon request.	Bearing: THK RA6008 or similar. Dia = 76 mm, C=5680 N, C _r =8680 N

ELECTRICAL INTERFACES	
Connectors: (Up to) 4x M8	1x Power supply, 2x <i>EtherCAT</i> (allows daisy-chaining of several systems), 1x fan power and control (radial connector version only).
<i>EtherCAT</i>	Full Duplex, 100 Mbit/s
Functional safety	Under development. Please contact us for details.
Grounding concept	All housing parts connected to DC link GND via RC network. <i>EtherCAT</i> shield connected directly to housing.
Fan power and control To to supply an external cooling fan.	Power: 12 V, max. 700 mA. Control: PWM (Open Drain, 25 kHz). Tacho input: Pull-up, 10 kΩ.

SYSTEM CONFIGURATIONS

We offer two connector arrangements of the *HEJ 90-48-140* to facilitate cable management and maximize systems integration possibilities.

All performance data is identical for the two versions.

Please refer to the mechanical drawings and electrical pinouts below to assess the key differences.

CAD models and detailed integration drawings are available on request.

Radial connectors

maxon P/N: 831220







Axial connectors

maxon P/N: 895330



ELECTRICAL PINOUTS – RADIAL CONNECTORS (P/N 831220, REV 05)

Steckerbelegung / PIN allocation		
Stecker/connector	PIN	Signal
X1 Power M8 male, 4poles, A-coded 	1	VBUS
	2	VBUS
	3	GND
	4	GND
X2 EtherCAT In M8 female, 4poles, A-coded 	1	TX+
	2	RX+
	3	RX-
	4	TX-

Steckerbelegung / PIN allocation		
Stecker/connector	PIN	Signal
X3 EtherCAT Out M8 female, 4poles, A-coded 	1	TX+
	2	RX+
	3	RX-
	4	TX-
X4 Fan M8 female, 4poles, A-coded 	1	VCC 12V
	2	GND
	3	PWM-Fan
	4	Tacho-Fan

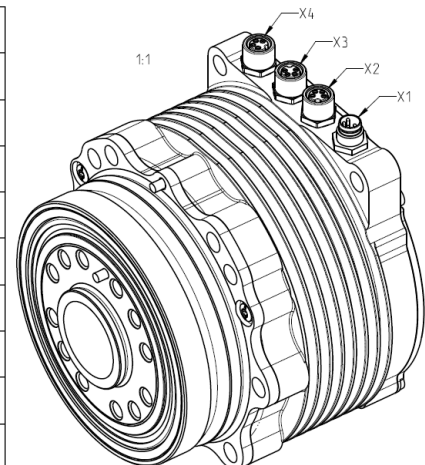

Please note:

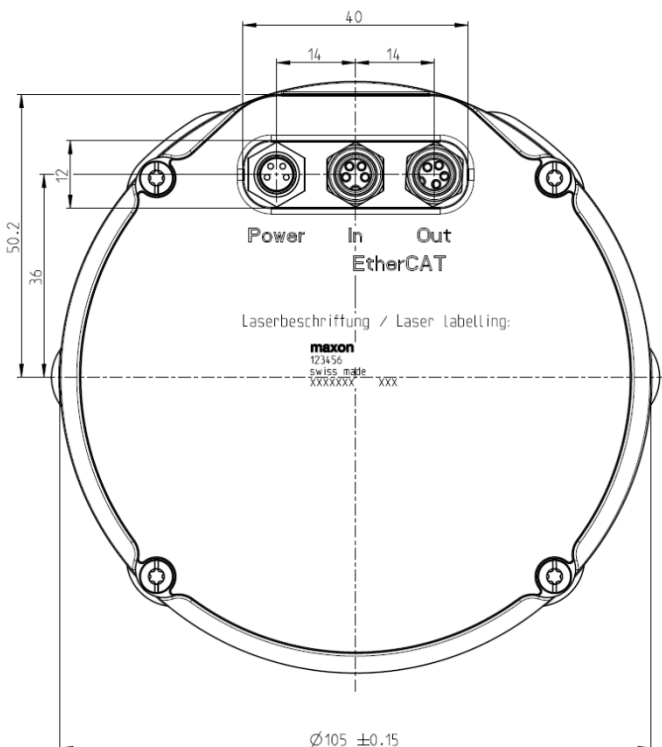
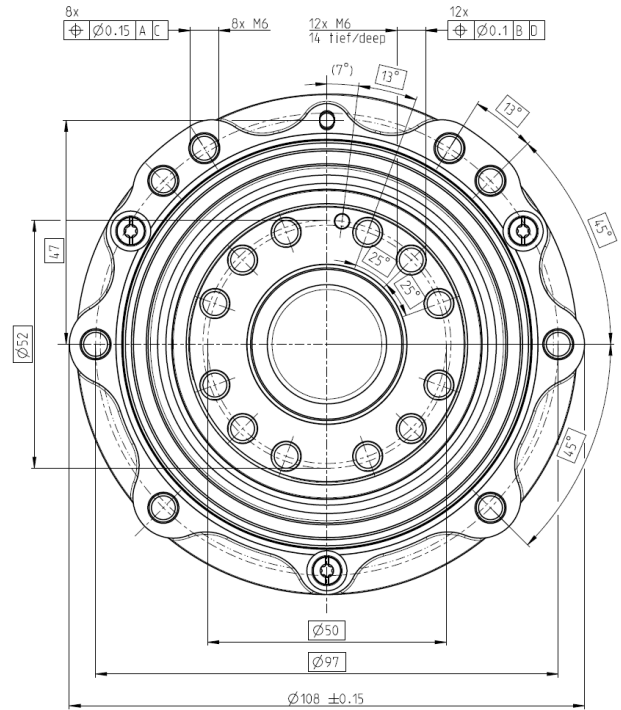
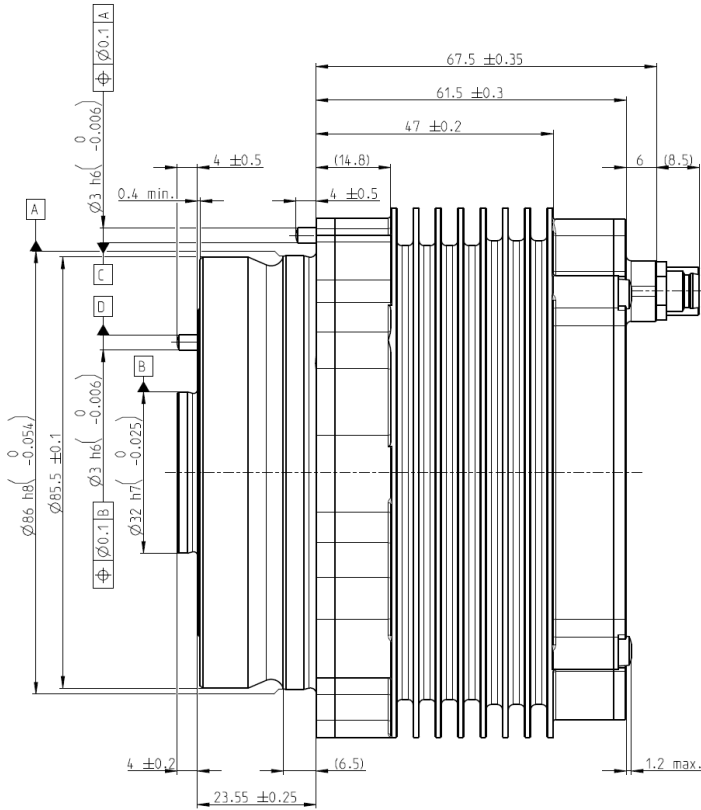

- 1) Due to technical limitations and design decisions, the mounting orientation (rotation) of the four connectors X1-X4 is arbitrary and cannot be changed (rotated). This means that the keys of these connectors can point in any direction. Do not use right-angled cables/connectors. Refer to the axial connector version of this unit (see below).
- 2) maxon can offer customized connectors or cabling solutions. Please contact robotics@maxongroup.com

MECHANICAL DRAWINGS – AXIAL CONNECTORS (P/N 895330, REV 02)

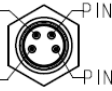

Please note: maxon can offer customized housing geometries, e.g., different thread sizes, hole patterns, or attachment points. Please contact robotics@maxongroup.com

ELECTRICAL PINOUTS – AXIAL CONNECTORS (P/N 895330, REV 02)

Steckerbelegung / PIN allocation		
Stecker/connector	PIN	Signal
X1 Power M8 male, 4poles, A-coded 	1	VBUS
	2	VBUS
	3	GND
	4	GND
X2 EtherCAT In M8 female, 4poles, A-coded 	1	TX+
	2	RX+
	3	RX-
	4	TX-
X3 EtherCAT Out M8 female, 4poles, A-coded 	1	TX+
	2	RX+
	3	RX-
	4	TX-

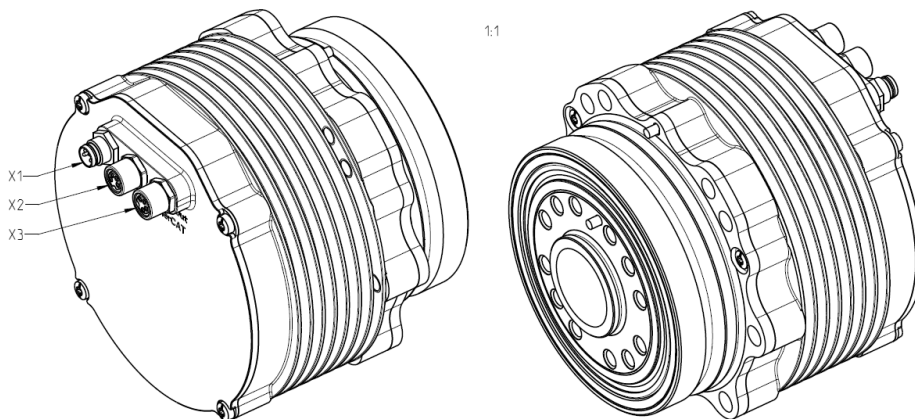

Please note:

- 1) Due to technical limitations and design decisions, the mounting orientation (rotation) of the three connectors X1-X3 is arbitrary and cannot be changed (rotated). This means that the keys of these connectors can point in any direction. Do not use right-angled cables/connectors. Refer to the radial connector version of this unit (see above).
- 2) maxon can offer customized connectors or cabling solutions. Please contact robotics@maxongroup.com